

“Parking with
pleasure...”



Parkolay

PHP 220F

Hydraulic Car Lift / Console Type Without Pit

The easiest solution to access parking floors.

Load capacity: max. 2.500 kg, wheel load 625 kg

Optional Load capacity: max. 3.000 kg, wheel load 750 kg



The driver can safely access to the garage floors with the car. The system is a space saver while compared to the conventional elevator's wide and deep pit dimensions. Also the system doesn't need any engine room. Full-length photo electric sensors at the front and rear of the platform that detect the position of the car, inform the driver about the car's position using audible and visual warning signs. The floor door opens automatically when the selected park floor is reached. The door closes automatically after the car exits.

ADVANTAGES »

- **Parkolay PHP 220F** is a space saver; you can access lower or upper parking floors easily with 300 cm width only, almost the length of your car, and with a 25 cm pit depth.
- The system can be easily integrated to the existing structure in the renovation projects.
- You may cover the system's entrance room, according to various architectural preferences.
- Different door selections are available.

Carlift Series



Otomatik Otopark Sistemleri
San. ve Tic. A. Ş.

Merkez Mah. Sardunya Cad.
No:8, Taşköprü, Yalova

T. +90 850 3333 667
F. +90 226 353 2774

www.otomatik.com.tr
info@otomatik.com.tr



System Measurements »

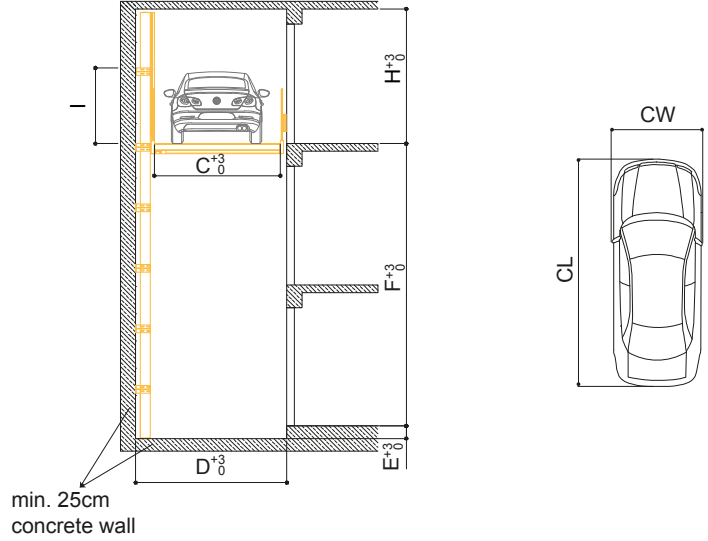
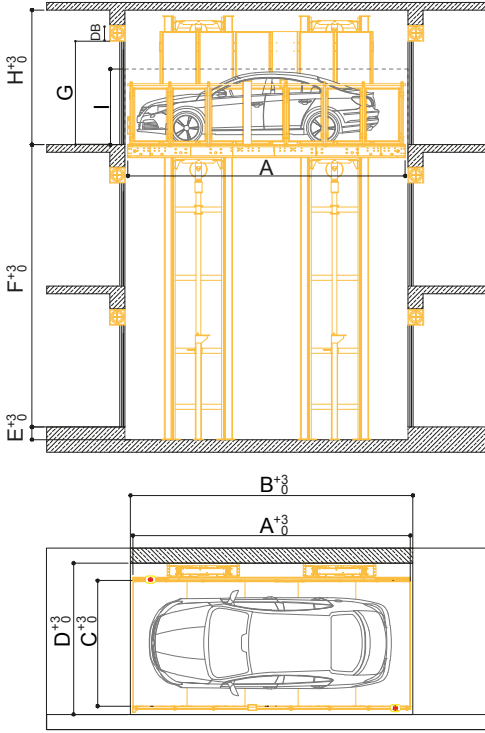

Structural Forces »

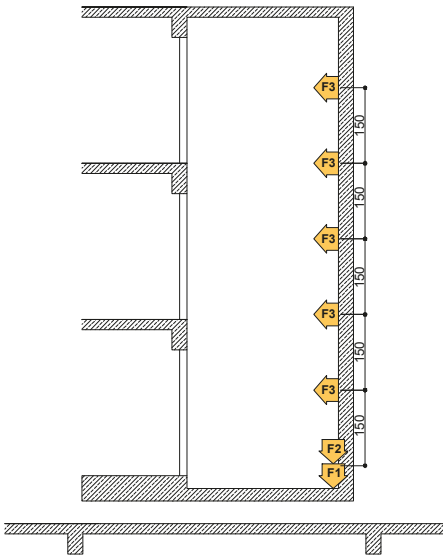

F1 = 30 kN
F2 = 5 kN
F3 = 10 kN

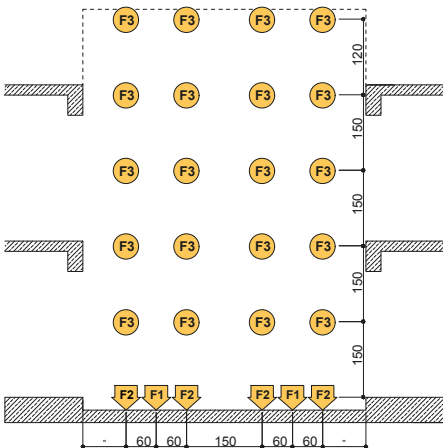

F1 = 30 kN
F2 = 5 kN
F3 = 10 kN

P Parkolay Hydraulic Car Lift without pit PHP 220F

Technical data

Dimensions are in cm.

Description	Dimensions	Standard	Maximum
Platform length	A	520	590
Pit length	B	530	600
Platform width	C	250	280
Pit width	D	300	330
Pit depth	E	25	50
(Pit depth with safety break)		75	75
Lifting height (min.)	F	< 1190	< 2190
Access height (min.)	G	210	210
Ceiling height	H	270	270
Top level load bearing height	I	minimum 120	
Rolling doors box size	DB	minimum 40X40	
Car dimensions	Weight	< 2.500 kg	< 3.000 kg
Length	CL	A-10	A-10
Width	CW	C-40	C-40

Technical features

Motor power	(kW)	13	15
Raising speed	V - (m/s)	0.15	0.15
Lowering speed	V - (m/s)	0.15	0.15

You may contact with the Parkolay for different dimension requirements.

Parkolay reserves the right to change specified features.

CE Machinery Directive 2006/42/EC

The Following Implementations Shall be Provided by Customer »

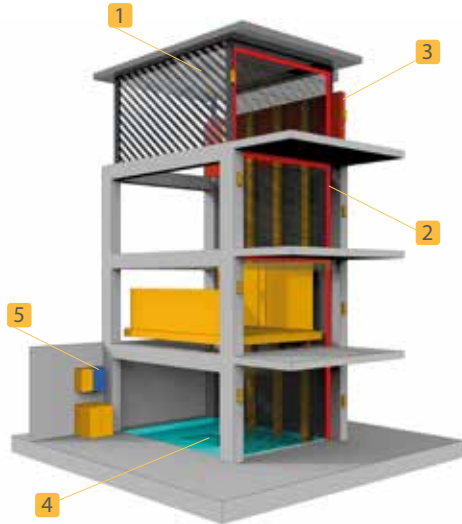

1 ENTRY - EXIT ROOM

If the platform is to be accessed from outdoors, it is necessary to cover the lift pit's surface and surroundings with suitable material according to the different architectural preferences. The system measurement chart must be followed for a better arrangement of the entry-exit room. Glass, polycarbonate, composite panel, wood etc. can be considered and applied.

2 DOOR FRAME

The system's entry and exit doors are supplied by Parkolay. However, the door frames and all other closures must be provided by the customer. Please contact Parkolay for more details.

3 SUPPORTED FRAMEWORK ON TOP FLOOR

The platform needs a supporting framework on one side of the top floor to support the system's guiding columns. The system measurement chart for reinforced concrete or steel carriers should be complied.

4 LIFT PIT DRAINAGE

In order to prevent any damages to the lift pit in case of water collection, The customer shall provide drainage channel and pump sump. Please contact Parkolay for more details.

5 SWITCH CABINET

Due to the building regulations, the energy provision must be provided by a switch cabinet with the generator support in accordance with local authorities and employer's standards. Please contact Parkolay for more details.

Options and Extra Equipment »



INTERNAL CONTROL



EXTERNAL CONTROL

2 DOUBLE SPEED According to the 2006/42 / EC directive; the driver can use the control panel from inside the cabinet if the speed is less than 0,15m/sec. Optionally, it can be controlled from outside the cab for higher speed.

3 SAFETY RAILING

Additional safety railing may be applied in front of the platform if needed.

1 UNINTERRUPTIBLE POWER SUPPLY (UPS)

When the power supply is disconnected due to any possible reason, the UPS allows the platform to be transported to the lowest floor and the door to be opened automatically for the vehicle to exit the system.

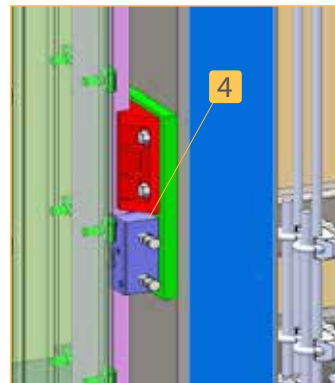

4 SAFETY BRAKE If the lift reaches an unexpected overspeed for any reason or the steel ropes are broken, the safety brakes are activated and prevent uncontrolled movement.

5 REMOTE ACCESS Optionally, remote access to the main control board via internet can be provided.

6 INTERCOM OR TELEPHONE Optionally, intercom or telephone can be included to provide communication within the platform.



System Components and Functions »



1



3

1 TRAFFIC LIGHT

Yellow: Platform is busy.

Yellow Flash: Platform is coming with car.

Green: Platform is empty and ready to use.

Green Flash: Platform is coming empty.

Red: Platform is out of service.



2 REMOTE CONTROL

You may call the platform to ground floor with remote control.

3 CONTROL PANEL WITH KEY SWITCH

The platform can be called through the control panels which located on each floor. The authorized user key and the emergency stop button of control panels on each floor ensure safe operation.



4 SIDE WALLS WITH INTERNAL CONTROL PANEL

There are polycarbon panels on both sides of the platform.

The side panel is located at the same height as the cabin, on the part where the profiles are. The other side panel is 120cm parapet height. By means of the internal control panel which is placed on the cabin wall in accordance with the height of the car, you can direct the platform to the desired floor. There is also an emergency button on the internal control panel.

5 SURFACE OF PLATFORM

Hot-dip galvanized sheet is used on the platform surface.

Optionally, diamond patterned aluminum sheet may be preferred.

6 FRONT AND BACK OPTIC SENSORS

There are optical sensors on the platform that control the position of the vehicle's front and rear.

7 FLASHER AND BUZZER

The flasher and buzzer on the system alert the driver until the vehicle is properly positioned.

8 DOORS ON THE FLOOR

Doors at each parking floor provide a secured entry into the system. The door opens automatically when the platform reaches the floor. The floor door closes automatically in the specified period of time after the car exiting the system.



9 FLOOR TRAFFIC LIGHT

Yellow: Platform is busy.

Yellow Flash: Platform is coming with car.

Green: Platform is empty and ready to use.

Green Flash: Platform is coming empty.

Red: Platform is out of service.

10 FLOOR CONTROL PANEL WITH KEY SWITCH

Call and emergency buttons are located on the control panel.

System Components and Functions »

11 MAIN CONTROL CABINET

Enough space should be allocated on the wall for the 80x140cm main control board.

12 HYDRAULIC POWER UNIT

The space required to place the hydraulic power unit must be allocated by the customer.

Dimension: 150x150cm

Required Power: 13kW



Operation Steps of the System »

The traffic lights next to the door follows a universal colour code.

Green: The green traffic light refers to the system being available to use, a call command may then be given via remote control or control panel. If the green light is blinking, the lift is coming without a car.

Amber(Yellow): The yellow traffic light refer to the system being busy. The platform is only called when the light is green. If the yellow light is blinking, the lift is transporting a car. Do not close the exit.

Red: The continuous flashing red light indicates that the system is out of service. If the light is blinking, the system is serviced in manual mode.



The following steps should be followed after calling the car;

- The door opens and the car is driven at slow speed(5km/s) to the platform. Meanwhile the auto-leveling system detects the weight and position of the vehicle when the vehicle is in the cabinet and provides lift leveling.



- When the car is entering the platform, the audible and illuminated warning system is activated. The warning stops automatically when the car is placed in the correct position. After this step the hand brake should be pulled and the engine stopped.



- The driver can use the control panels on both sides of the platform, from inside the vehicle.

- When the car arrives to the targeted floor, the floor door is automatically opened and the car can exit the system.

- The floor door closes automatically in the specified period of time after the car exiting the system.



Corrosion Protection and Prevention



Besides the maintenance, the systems have to be cleaned regularly. This applies to the systems' platforms and all parts being exposed to corrosive substances, e.g. salt water, dirt, car fluids, sand, etc. Garages also have to be ventilated and deaerated, The base plates have to be dewatered and dry.

Fire Safety

Designing fire safety in the proposed garage or area must comply with the local/ regional regulations. The compliance must be managed by customer. Depending on the location and the fire department there might be very different and specific requirements. The customer should inform the supplier about regulations in advance.



Water Evacuation



Dewatering involves controlling water in the system area with the possibility of pumping it out of a water collecting pump sump. Water may occur from snow on the car, leaking shell, ground water, wet cleaning etc. It can be solved by a drainage system 10/ 2 cm with pump sump (50 x 50 x 20 cm). There should be no water in the lift pit.

Car Development

The size and weight of the new generation of cars have been increased due to the extra equipment, which means that the weight of upper middle class cars oftenly exceed 2000kg. Parallely to that, the manufacturer offers a standard 2.500kg lifting capacity and 625kg wheel load. Optionally, the 3.000kg lifting capacity / 750kg wheel load can be provided for heavier cars.



Sound Insulation EN 14366 : 2004



"Sound insulation in buildings". According to the German norm a value of 30 dB(A) is allowed in living quarters. This can be fulfilled through the noise protection option applied according to the supplier's offer. Sound insulation of building R'w = 57 dB. Surrounding walls/ ceilings (e.g. monolithic and rigid) of parking should be made of min m' = 300/ 400 kg/ m². The adjacent critical building element should be min m' = 580 kg/ m². User noises are created by individual users. These can be from driving up/ down the platforms, slamming of vehicle doors, motor and brake noises. They are not subject to the limit. "Increased sound insulation" is made on special offer and discussion. This option requires more space allocation.

MINIMUM DIMENSIONS & TOLERANCES »

All shown dimensions are minimum. Tolerances according to VOB part C (DIN 18330 and 18331) and the DIN 18202 have to be considered additionally. Tolerances for space requirements are +3 cm/ 0 cm. Dimensions are expressed in cm.

ENVIRONMENTAL RANGE »

Temperature range -10 to +40° C. Relative humidity 50% at maximum outside temperature of +40° C.

LIGHTING »

Customer must provide sufficient lighting in the parking garage and shaft of the lift according to the regulations.

CE AND CONFORMITY »

The systems correspond to the EC Machinery Directive 2006/42/EC.

RIGHTS TO CHANGE »

The manufacturer reserves the right to make changes and/or improvements in model & dimensions without prior notice.

The general planning/ supply of the garage with the building structure, statics, tolerances, free spaces, wall cutting, drainage, noise protection, fire demands, electricity, grounding, driveway, illumination, ventilation, marking fences and others has to be arranged according to local requirements by the customer and must be in accordance with the delivery/ requests of the manufacturer.